

# GROVE®

# RT9130E

## product guide

 120 tonnes

 48.6 m

 11 - 34 m

 85 m



Rough Terrain Crane • Geländekran • Grue Tout-Terrain  
Grúa Todo Terreno • Autogru Fuoristrada

## Contents • Inhalt • Contenu • Contenido • Contenuto

2

<b>Specification</b>	<b>3</b>
<b>Technische Daten</b>	<b>4</b>
<b>Caractéristiques techniques</b>	<b>5</b>
<b>Características</b>	<b>6</b>
<b>Caratteristiche</b>	<b>7</b>
<b>Dimensions • Abmessungen • Enncombrement • Dimensiones • Dimensioni</b>	<b>8</b>
<b>Data • Daten • Caractéristiques • Datos • Dati</b>	<b>9</b>
<b>Load charts • Traglasten • Capacités de levage • Capacidades • Capacità</b>	
Notes • Hinweise • Notes • Notas • Note	10
Working Range • Arbeitsbereiche • Diagramme de levage • Gama de trabajo • Area di lavoro	11
Telescopic Boom • Teleskopausleger • Flèche principale • Pluma telescópica • Braccio telescopico	12
Swingaway • Klappspitze • Extension treillis • Plumín • Jib	14
Weight Reductions • Gewichte der Lastaufnahmemittel • Réductions de charge • Reducciones de peso • Riduzioni di peso	17
<b>Notes • Hinweise • Notes • Notas • Note</b>	
Symbols • Symbolerklärung • Glossaire des symboles • Glosario de simbolos • Glossario dei simboli	19

RT9130E

GROVE®

## Superstructure

### Boom

12.8 m to 48.6 m five section full power boom. Auxiliary boom nose and boom removal equipment. Maximum tip height 51.5 m.

### Swingaway

Bi-fold swingaway, 11/18 m (offsets 0°, 20°, 40°). Maximum tip height 69.2m.

### Boom elevation

1 cylinder with safety valve, boom angle from -3° to 78°.

### Load moment and anti-two block system

Standard "Graphic Display" load moment and anti-two block system with audio-visual warning and control lever lockout. These systems provide electronic display of boom angle, length, radius, tip height, relative load moment, maximum permissible load, load indication and warning of impending two-block condition. The standard Work Area Definition System allows the operator to pre-select and define safe working areas. If the crane approaches the pre-set limits, audio-visual warnings aid the operator in avoiding job-site obstructions. LMI light bar.

### Cab

Galvanealed steel, tiltable (approx 20°) acoustically treated, opening skylight with electric wiper and skylight sunscreen, deluxe seat with armrest-integrated crane controls, engine dependent hot water heater. Ergonomically arranged instrumentation and crane operating controls. Drive/steer controls.

### Slewing

360° continuous rotation, planetary glide swing with foot applied brake. Spring applied hydraulically released parking brake and plunger type, 2 position mechanical house lock. 360° mechanical slew lock operated from cab.

### Counterweight

18,144 kg. Hydraulic removal system.

### Hydraulic system

6 main gear pumps combined capacity 776 l/min. Return line filter with by-pass protection. Remote mounted thermostatically controlled oil cooler and system pressure test ports. Pump disconnect. Tank capacity: 1230 l.

### Control system

Stepless control of all crane movements using single axis hydraulic pilot control levers with automatic reset to zero.

### Hoist

Main and auxiliary hoists, axial piston motor with planetary gear, dual speed with automatic spring applied multi-disc brake. Grooved drum, hoist drum cable followers and electronic rotation indicator. 6x37 class hoist rope for 3.5:1 F.O.S.

### \* Optional equipment

Bi-fold swingaway, 11/18 m – with hydraulic offset and luffing under load (5° - 40°), controlled from the crane cab.

35x7 class hoist rope for 5:1 F.O.S.

8/16 m fixed lattice insert for swingaway.

Air conditioning

## Carrier

### Carrier frame

Special 2-axle carrier, all-welded torsion-resistant box type construction in high strength steel. Integral towing and tie down lugs.

### Outriggers

4 hydraulically telescoping beams with 'inverted' jacks and 775 mm diameter outrigger pads. Removable outrigger boxes. Independent horizontal and vertical movement control from the crane operator's cab. Two position setting. Sight level gauge. Maximum outrigger pad load: 75,298 kg.

### Engine

Cummins QSC8.3-300, 6 cylinder water cooled, turbocharged diesel. 224 kW (300 bhp) at 2200 rpm. Max. torque: 1356 Nm at 1300 rpm. Fuel tank capacity: 379 l. Engine emission: EUROMOT / EPA CARB (non road). Engine block heater.

### Transmission

Clark powershift R36000 series, 6 forward and 3 reverse speeds.

### Drive/Steer

4 x 4 x 4

### Axles

2 axles driven and steered. Front axle disconnect for 4 x 2 travel.

### Suspension

Front axle rigid mounted to frame. Rear axle pivot mounted. Automatic oscillation lockouts permit oscillation only with boom centred over front.

### Tyres

4 tyres, 33.25 x 29 - 38 PR earthmover type.

### Steering

Front, full hydraulic steering wheel controlled. Separate steering of the rear axle for rear, crab and coordinated steering.

### Brakes

Service brake: hydraulic dual circuit acting on all wheels. Parking brake: spring-applied, hydraulically released on front axle.

### Electrical system

12 V (Two 12 V maintenance free batteries).

### \* Optional equipment

CE Mark Conformance.

Cross axle differential locks

Rear pintle hook.

## Technische Daten

### Kranoberwagen

#### Teleskopausleger

12,8 m bis 48,6 m vollhydraulisch teleskopierbarer 5-Stufen-Ausleger. Hilfsrollenkopf und Ausleger Demontagevorrichtung. Maximale Rollenhöhe 51,5 m.

#### Klappspitze

Doppelklappspitze 11/18 m (0°, 20°, 40° abwinkelbar). Maximale Rollenhöhe 69,2 m.

#### Wippwerk

1 Hubzylinder mit Sicherheitsventil, Auslegerwinkel -3° bis 78°.

#### Lastmomentbegrenzer und Hubendabschaltesystem

Standard "Grafische Darstellung" Lastmomentbegrenzer und Hubendabschaltesystem mit audio-visueller Warneinrichtung und Bedienelementabschaltung. Diese Systeme bieten eine elektronische Anzeige von Auslegerwinkel, Auslegerlänge, Ausladung, Rollenhöhe, relative Last, maximal zulässige Last, tatsächliche Last sowie eine Hubende-Warneinrichtung.

Durch die Arbeitsbereich-begrenzung kann der Bediener sichere Arbeitsbereiche definieren. Fährt der Kran auf die Begrenzung des sicheren Arbeitsbereichs zu, wird der Bediener hörbar und visuell gewarnt. So können Kollisionen auf der Baustelle vorgebeugt werden. LMB (Lastmomentbegrenzer). Leuchtbalkenanzeige

#### Kabine

Verzinkte, schallgedämmte Stahlkabine, ca. 20° Kippbar, aufklappbares Dachfenster mit elektrischem Scheibewischer und Sonnenschutz, Komfortsitz mit in die Armlehnen integrierten Bedienelemente, motorabhängige Heisswasserheizung. Ergonomisch angeordnete Bedienelemente und Kranbedienelement. Fahr- und Lenkbedienung.

#### Drehwerk

360° rundum kontinuierlich schwenkbar, Planetenschwenkwerk mit Fusspedalschwenkbremse. Hydraulisch lösbare Federspeicher-Feststellbremse und mechanische, in 2 Stellung verriegelbare Bolzenverriegelung. Von der Kabine aus bedienbare mechanische 360°-Schwenkwerkverriegelung.

#### Gegengewicht

18144 kg. Hydraulisches Rüstsystem.

#### Hydrauliksystem

6 Hauptzahnradpumpen mit einer Gesamtfördermenge von 776 l/Min. Filter mit Vollstrom-Überströmventil im Rücklauf. Abgesetzt montierter, thermostatisch geregelter Ölkühler und Druckkontrollanschlüsse. Pumpenabschaltung. Tankfassungsvermögen: 1230 l.

#### Steuerung

Stufenlose Bedienung aller Kranbewegungen mittels hydraulischer Einachs-Bedienelement mit automatischer Rückführung in die Nullstellung.

#### Hubwerk

Haupt- und Hilfswinde, Axialkolbenmotor mit Planetengetriebe, zwei Geschwindigkeitsstufen mit automatischer Federspeicher-Lamellenbremse. Gerillte Seiltrommel, Windenseilführung und elektronische Umdrehungsanzeige. Typ 6x37 Hubseil für 3.5:1 Sicherheitsfaktor.

#### \* Zusatzausüstung

Doppelklappspitze 11/18m Anlenkung 5° - 40°. Aus der Kranfahrerkabine hydraulisch einstellbar und unter Teillast wippbar. Typ 35x7 Hubseil für 5:1 Sicherheitsfaktor. 8/16 m Verlängerung für Doppelklappspitze. Klimaanlage.

### Kranunterwagen

#### Rahmen

2-Achsen-Spezial-Unterwagenrahmen, vollverschweißte, verwindungsfeste Kastenprofil-Konstruktion aus hochfestem Stahl. Integrierte Schlepp- und Verstaueisen.

#### Abstützung

4 hydraulisch teleskopierbare Abstützträger mit innengeführten Stützzyllindern und 775 mm (Durchmesser) Abstützstellern. Abnehmbarer Abstützkasten Unabhängige Bedienung der horizontalen und vertikalen Bewegungen von der Krankabine aus. Teilauslage in 2 Stellungen verbolzbearbeitet. Nivellierlibelle. Maximale Stütztellerlast: 75,298 Kg.

#### Motor

Cummins QSC8.3-300, wassergekühlter 6-Zylinder-Turbodieselmotor. 224 KW (300 PS) bei 2200 U/Min. Max. Drehmoment: 1356 Nm bei 1300 U/Min. Fassungsvermögen Treibstofftank: 379 l. Abgasemission: EUROMOT / EPA / CARB (nicht Strasse). Motorblock-Heizung.

#### Getriebe

Clark Powershiftautomatikgetriebe Serie R36000, 6 Vorwärtsgänge und 3 Rückwärtsgänge.

#### Antrieb/Lenkung

4 x 4 x 4

#### Achsen

Zwei Achsen angetrieben und lenkbar. Vorderachse für 4 x 2 Fahrt abschaltbar.

#### Federung

Vorderachse starr am Unterwagenrahmen montiert. Hinterachse als Pendelachse montiert. Die automatische Federungsverriegelung entriegelt die Federung nur dann, wenn der Ausleger nach vorn zeigt.

#### Bereifung

4 Reifen, 33.25 x 29 - 38 PR Radladerreifen.

#### Lenkung

Vorn vollhydraulische Lenkung mittels Lenkrad. Separate Lenkung der Hinterachse für hintere Lenkung, Hundegang oder koordinierte Lenkung.

#### Bremsen

Betriebsbremse: Zweikreis-Hydraulik-Bremssystem, auf alle Räder wirkend. Feststellbremse: Hydraulisch lösbare Federspeicher-Feststellbremse an der Vorderachse montiert.

#### Elektrische Anlage

12 V (Zwei 12 V wartungsfreie Batterien).

#### \* Zusatzausrüstung

CE Zertifikat. Querdifferentialsperren Abschlepphaken.

## Superstructure

### Flèche

Flèche cinq éléments de 12,8 m à 48,6 m à télescopage hydraulique. Tête de flèche auxiliaire et dispositif de dépose de flèche. Hauteur max. de tête de flèche 51,5 m.

### Extension treillis

Extension treillis à repliage latéral double de 11/18 m (inclinable à 0°, 20°, 40°). Hauteur max. de tête de flèche 69,2 m.

### Relevage

1 vérin avec clapet anti-retour, angle de flèche de -3° à + 78°.

### Contrôleur d'état de charge et dispositif de fin de course haute

Contrôleur d'état de charge à affichage graphique et dispositif de fin de course haute avec alarme sonore et visuelle et dispositif de coupure des mouvements. Ces dispositifs électroniques affichent les indications d'angle et de longueur de flèche, de portée, de hauteur de tête de flèche, de moment relatif, de charge maximum admissible, de charge levée et d'approche de bloc à bloc. Le dispositif de définition de domaine de travail, monté de série, permet à l'utilisateur de définir des limites de zone de travail. Si la grue approche ces limites, des alarmes sonores et visuelles préviennent l'utilisateur. Barre de répétition d'affichage de moment C.E.C.

### Cabine

Cabine en tôle galvanisée, inclinable (environ 20°) insonorisée, avec baie de toit ouvrante, essuie glace électrique et rideau pare-soleil, siège capitonné avec commandes de grue montées sur les accoudoirs, chauffage à eau chaude alimenté par le moteur thermique. Disposition ergonomique de l'instrumentation et des commandes de grue. Commandes de conduite pour le déplacement et la direction du porteur.

### Orientation

Orientation continue sur 360° avec réducteur à planétaires « glide swing » et frein au pied. Frein d'immobilisation à serrage par ressorts et desserrage hydraulique. Axe de verrouillage d'orientation sur deux positions. Dispositif de verrouillage mécanique sur 360°, commandé depuis la cabine.

### Contrepoids

18.144 kg. Système de dépose hydraulique.

### Circuit hydraulique

6 pompes principales à engrenages ayant un débit total de 776 l/min. Filtration sur circuit retour avec circuit « by-pass ». Refroidisseur d'huile hydraulique à commande thermostatique monté à distance et panneau de prises de pressions centralisées. Débrayage de pompe. Capacité du réservoir : 1230 l.

### Commandes de grue

Commandes progressives par leviers simple axe et retour au neutre automatique.

### Treuil

Treuil de levage principal et auxiliaire, moteurs à pistons axiaux avec réducteur à planétaires, deux vitesses avec frein automatique à serrage par ressorts et desserrage automatique. Treuil rainuré, rouleau presse câble et indicateur électronique de rotation du tambour. Câble de levage classe 6x37 donnant un coefficient de sécurité de 3.5:1

### \* Equipements optionnels

Extension treillis à repliage latéral double de 11/18 m – avec déport hydraulique et inclinaison sous charge (5° - 40°), commandés depuis la cabine.

Câble de levage classe 35x7 donnant un coefficient de sécurité de 5:1  
Élément intermédiaire fixe de 8/16 m pour l'extension treillis.  
Climatisation.

## Porteur

### Châssis porteur

Châssis caissonné, mécanosoudé, spécifique, à 2 essieux, en tôles d'acier à haute limite élastique, avec oreilles de remorquage et d'arrimage intégrées.

### Calage

4 poutres à télescopage hydraulique avec vérins verticaux en position « inversée » et semelles d'appui carrées de 775 mm de diamètre. Caissons calage démontables. Commande indépendante des mouvements de sortie de poutres et de vérins depuis le poste de pilotage. Deux configurations de calage sont autorisées. Niveau à bulle. Charge maximum sur les appuis: 75,298 kg.

### Moteur

Moteur Diesel Cummins QSC8.3-300, 6 cylindres, à refroidissement liquide et dispositifs de suralimentation. 224 kW (300 CV) à 2200 tr/min. Couple max.: 1356 Nm à 1300 tr/min. Capacité du réservoir de carburant : 379 l.

Emissions de gaz polluants: EUROMOT / EPA CARB (normes chantier). Réchauffage du bloc-moteur

### Boîte de vitesses

Boîte de vitesses Clark R36000, 6 rapports de marche avant et 3 rapports de marche arrière.

### Direction/Déplacement

4 x 4 x 4

### Ponts

2 ponts moto-directeurs. Pont avant débrayable pour déplacements sur route.

### Suspension

Pont avant rigide fixé au châssis. Pont arrière articulé. Le dispositif automatique de verrouillage d'articulation libère la suspension lorsque la flèche est centrée sur l'avant.

### Pneumatiques

4 pneumatiques 33.25 x 29 - 38 PR de type chantier.

### Direction

Direction avant hydraulique commandée par volant. Direction indépendante pour les roues arrière donnant les configurations : direction arrière, marche en crabe et direction coordonnée.

### Freins

Frein de service: double circuit hydraulique agissant sur toutes les roues. Frein de stationnement: à serrage par ressorts et desserrage hydraulique agissant sur lessieu avant.

Circuit électrique

12 V (Deux batteries 12 V sans entretien).

### \* Equipements optionnels

Conformité CE.

Blocages de différentiels inter-roues.

Crochet de remorquage.

## Características

### Superestructura

#### Pluma

De 12,8 m. hasta 48,6 m. en 5 tramos de telescopaje totalmente hidráulico. Cabeza auxiliar de pluma tipo nariz y equipo desmontable de pluma. Altura máxima en punta 51,5 m.

#### Plumín

Plumín articulado en 2 secciones, 11/18 m (angulable 0°, 20°, 40°). Altura máxima en punta 69,2 m.

#### Elevación de pluma

Un cilindro con válvula de seguridad. Angulo de pluma desde -3° hasta 78°.

#### Sistema Indicador del Momento de Carga y de Final de Carrera del Gancho

La Pantalla Gráfica estandar. Indicador del momento de carga y de final de carrera del gancho con alarma audiovisual y bloqueo automático de las palancas de control. Estos sistemas proporcionan información en la pantalla del ángulo de pluma, longitud, radios, altura, momento de carga relativo, carga máxima permitida, indicador de carga y alarma de final de carrera del gancho. El sistema estandar de Area Definida de Trabajo permite al operador preseleccionar y definir las zonas seguras de trabajo. Si la grúa se acerca a los límites preseleccionados, la alarma audio-visual avisa al operario para evitar obstrucciones en el lugar de trabajo. Tubo de iluminación del Indicador de cargas.

#### Cabina

De acero galvanizado, basculable (aprox. 20°), tratada acústicamente, ventana superior abatible con limpia-parabrisas eléctrico y persiana parasol en techo, asiento de lujo con controles de operación de la grúa e instrumentación ergonómicamente situadas, calefacción por agua caliente del motor. Controles de traslación/dirección.

#### Giro

Continuo a 360°, giro deslizante con planetarios y freno actuado por pedal. Freno de aparcamiento aplicado por muelle con desconexión hidráulica y pistón, bloqueo mecánico en 2 posiciones. Bloqueo mecánico de giro en los 360° accionado desde la cabina. Aire acondicionado.

#### Contrapeso

De 18.144 kg. Sistema hidráulico para desmontaje.

#### Sistema hidráulico

6 bombas principales de engranaje con una capacidad combinada de 776 litros/minuto. Filtro en la línea de retorno con protección by-pass. Radiador de refrigeración de aceite con control por termostato y sistema de comprobación de presión en el panel. Desconector de la bomba. Capacidad del depósito 1230 litros.

#### Sistema de Control

Controles continuos de todos los movimientos de la grúa, usando palancas de control con retorno automático a cero.

#### Cabrestante

Principal y auxiliar, con motor de pistón axial, engranaje planetario, dos velocidades con freno automático multidisco aplicado por muelle. Tambor acanalado, ordenador de cable en el tambor e indicador de dirección. Cable del cabrestante con un factor de seguridad de 3.5 a 1.

#### \* Equipos Opcionales

Plumín articulado en 2 secciones, 11/18 m – con angulación fija y variable, con carga (5° - 40°) de accionamiento hidráulico. Cable 35x7 con un factor de seguridad de 5 a 1. Tramo de celosía de 8/16 m. para extensión abatible. Aire acondicionado.

### Chasis

#### Bastidor

Chasis especial de dos ejes de construcción soldada tipo cajón resistente a la torsión, en acero de alta resistencia. Gancho de arrastre y orejetas de amarre.

#### Estabilizadores

4 vigas telescópicas hidráulicas con cilindros verticales invertidos y placas de apoyo cuadradas de 775 mm. de superficie. Cajones de gatos desmontables. Controles independientes para los movimientos horizontales y verticales desde la cabina del operador. 2 posiciones de aplicación. Manómetro indicador de nivel. Carga máxima en cada placa de apoyo 75,298 kg.

#### Motor

Diesel Cummins QSC8.3-300, 6 cilindros, refrigerado por agua, turbo-aliimentado, 224 Kw (300 bhp) a 2.200 rpm. Par máximo: 1356 Nm a 1.300 rpm. Depósito de combustible: 379 litros. Emisión de gases: EUROMOT/EPA/CARB (non-road). Calentamiento del bloque motor.

#### Transmisión

Clark powershift serie R36000, 6 velocidades adelante y 3 atrás.

#### Tracción/Dirección

4 x 4 x 4

#### Ejes

2 ejes motrices y directrices. Eje delantero desconectable para desplazamiento 4x2.

#### Suspensión

Montaje rígido al bastidor en el eje delantero. En el eje trasero pivotante. Bloqueo automático de oscilación únicamente con la pluma centrada por la parte frontal.

#### Neumáticos

4 de 33.25x29-38 lonas, tipo movimiento de tierras.

#### Dirección

Delantera, completamente hidráulica con control por volante. Control independiente del eje trasero para dirección trasera, tipo cangrejo y coordinada.

#### Frenos

De Servicio: Hidráulicos de doble circuito, actuando sobre todas las ruedas. De Aparcamiento: Aplicado por muelle con desconexión hidráulica sobre el eje delantero.

#### Sistema eléctrico

12 V (dos baterías de 12 V sin mantenimiento).

#### \* Equipos Opcionales

Complimiento de las Directivas Comunitarias. Bloqueo cruzado del diferencial. Gancho de arrastre trasero.

6

RT9130E

GROVE®

\*Otros opcionales a petición

## Torretta

### Braccio

Da 12,8 a 48,6 m, 5 sezioni con sfilamento completamente idraulico. Falconcino di servizio ed accessori per la rimozione del braccio. Altezza massima: 51,5 m.

### Jib

Jib ripiegabile da 11/18 m, inclinabile da 0°, 20°, 40°. Altezza massima: 69,2 m.

### Sollevamento Braccio

Un cilindro idraulico con valvola di blocco, angolo braccio da -3° a +78°.

### Limitatore di carico e blocco dei movimenti

Display grafico standard per limitazione di carico e blocco dei movimenti con allarme visivo e sonoro e controllo dell'esclusione delle leve. Questo sistema è provvisto di display elettronico riportante l'angolo e la lunghezza del braccio, il raggio di lavoro, l'altezza di lavoro, il momento, il peso ammissibile, il peso attuale. Allarme di blocco sui movimenti. Lo standard Work Area Definition System permette all'operatore di preselezionare e definire le aree di lavoro sicure. Se l'autogrù si avvicina ai limiti preselezionati, l'allarme visivo e sonoro aiuta l'operatore a evitare difficoltà sul lavoro. Barre luminose LMC

### Cabina

Costruita in acciaio galvanizzato, inclinabile (20° circa), insonorizzata, vetro superiore apribile con tergicristallo elettrico e tendina parasole, comodo sedile con comandi integrati nei braccioli, strumentazione ergonomica, comandi sterzo e guida. Riscaldamento ad acqua dipendente dal motore.

### Rotazione

Rotazione continua a 360° con riduttore a planetari con freno a pedale. Freno di parcheggio rilasciato idraulicamente tramite molle e bloccaggio con perno meccanico in 2 posizioni. Bloccaggio meccanico della rotazione a 360° controllato dalla cabina dell'autogrù.

### Contrappeso

Da 18.144 kg. Sistema di rimozione idraulico.

### Impianto idraulico

3 pompe principali a ingranaggi con capacità totale di 776 l/min. Filtro sul ritorno con protezione by-pass. Raffreddamento olio idraulico con controllo termostatico montato a parte e collegamenti per controllo pressione del sistema. Pompa scollegabile. Capacità del serbatoio: 1230 l.

### Comandi

Tutti i movimenti della gru sono controllati continuamente con leve di comando a regolazione idraulica per ogni manovra con richiamo automatico al punto zero.

### Argano

Argano principale ed ausiliario, motore a pistoni assiali con riduttore a planetari a due velocità con freno automatico a dischi. Tamburo scanalato, guide per cavo tamburo argano e indicatore di rotazione elettronico. Fune classe 6x37 per fattore di sicurezza 3,5:1. Indicatore di rotazione argano.

### \*Accessori opzionali

Jib ripiegabile da 11/18 m, con sistema di brandeggio idraulico anche sotto carico (5° - 40°), controllato dalla cabina della gru. Fune classe 35x7 per fattore di sicurezza 5:1. Prolunghe tralicciate per jib ripiegabile 8/16 m. Aria condizionata

## Carro

### Telaio

Carro speciale, 2 assi, costruzione in acciaio scatoletto ad alta resistenza, resistente alla torsione. Occhioni di traino integrati.

### Stabilizzatori

4 travi telescopiche orizzontali idrauliche con cilindri verticali e piatti d'appoggio con una superficie del piatto di 775mm. Gruppo stabilizzatori rimovibile. Comandi indipendenti dei movimenti orizzontali dalla cabina del carro. 2 configurazioni di bloccaggio. Indicatore livello a bolla. Carico massimo piatti stabilizzatori 75298 kg

### Motore

Cummins QSC8.3-300, 6 cilindri, turbo 224Kw (300 bhp) a 2200 giri al minuto. Coppia max: 1356 Nm a 1300 giri al minuto. Capacità del serbatoio: 379 l.

Emissioni gassose allo scarico: EUROMOT/EPA CARB (no su strada). Riscaldamento del blocco motore.

### Cambio

Cambio Clark automatico R36000, 6 marce avanti più 3 retromarcia.

### Trazione/Sterzo

4x4x4

### Assali

2 assi sterzanti e di trazione. Possibilità di non azionare l'asse anteriore per percorsi 4x2.

### Sospensioni

Asse anteriore montato fisso sul telaio del carro. Asse posteriore articolato. Il dispositivo automatico di bloccaggio sospensioni sblocca la sospensione solo se il braccio è centrato in avanti.

### Pneumatici

4 pneumatici, 33,25x29-38 PR tipo movimento terra.

### Sterzo

Sterzo anteriore completamente idraulico tramite il volante. Sterzo separato dell'asse posteriore per sterzata posteriore, a granchio e combinata.

### Freni

Freno di servizio: idraulico a doppio circuito, agente su tutte le ruote. Freno di parcheggio: con molle precaricate a comando idraulico montato sull'assale anteriore.

### Impianto elettrico

12V (2 batterie) da 12V senza manutenzione

### \*Equipaggiamenti opzionali

Certificato CE.

Differenziale autobloccante

Gancio per rimorchio

Dimensions • Abmessungen • Encombrement • Dimensiones • Dimensioni

8

	A	B	C	D	E	F	G
4 x 4 x 2	18237	18847	15748	14864	14453	11710	10237
4 x 4 x 4	13310	13818	10262	9398	8967	6198	5588

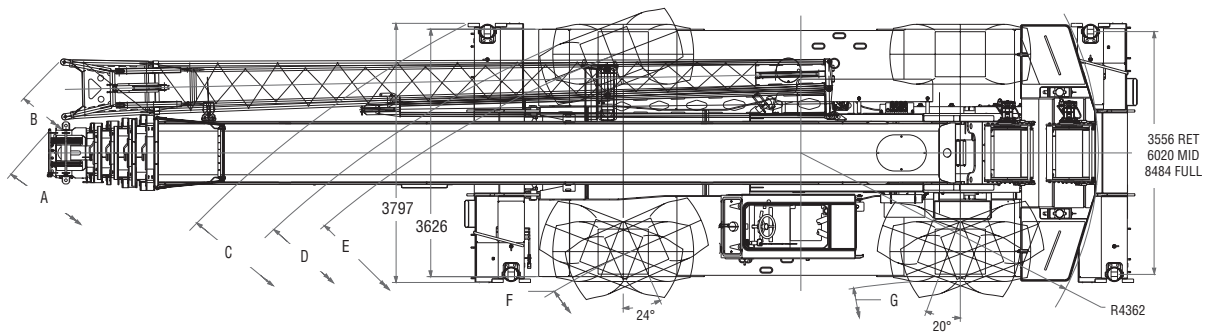
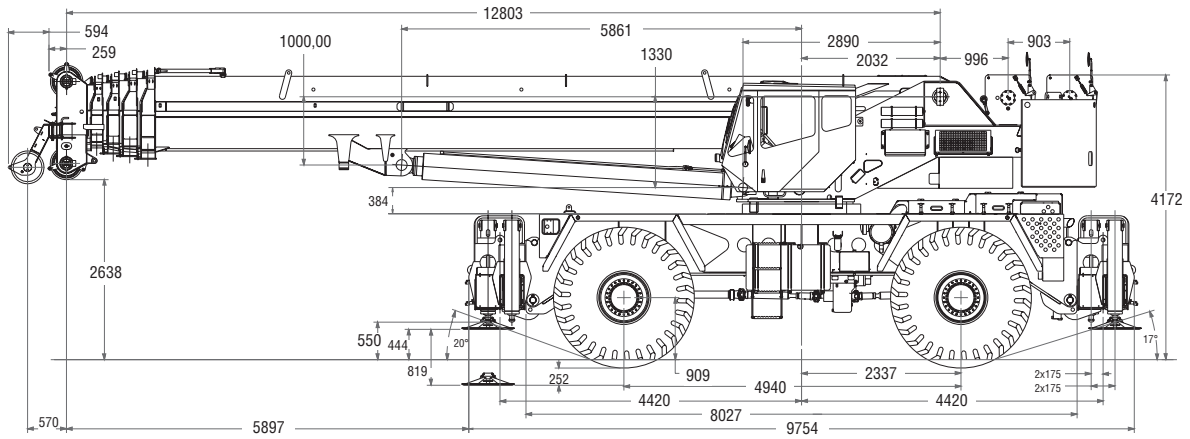

Total weight / Gesamtgewicht / Poids total / Peso total / Peso totale	77.9 t
<b>Weight reductions / Gewichtsreduzierung / Réductions de poids / Reducciones de peso / Riduzioni di peso</b>	
Counterweight / Gegengewicht / Contrepoids / Contrapeso / Contrappeso	18.1 t
Boom / Teleskopausleger / Flèche / Pluma / Braccio	15.2 t
Outrigger boxes / Stutzkasten / Caisson calage / Estabilizadores / Cassa stabilizzatori	8.5 t
Tyres / Bereifung / Pneumatiques / Neumáticos	4.3 t
Auxiliary hoist / Hilfshub / Treuil auxiliaire / Cabrestante auxiliar / Secondo argano	1.9 t
Bi-fold swingaway / Doppelklappspitze / Extension Treillis à repliable double / Plumin articulado en 2 secciones / Prolunga tralicciata pieghevole	1.4 t

RT9130E

GROVE





Axle Achse Essieu Eje	1	2	Total weight Gesamtgewicht Poids total Peso total
t	34.8	43.1	77.9

\* incl. 18 m Swingaway, incl. 18 m Klappspitze, incl. extension treillis 18 m, incl. plumín de 18 m, inc. jib 18m



Lifting Capacity Traglast Force de levage Capacidad de elevación	Sheaves Rollen Pulies Poleas	Parts of line Stränge Brins Ramales de cable	Weight Gewicht Poids Peso
118 t	8	2 - 16	1181 kg
70 t	5	2 - 10	725 kg
9.1 t	H/B (swivel)	1	318 kg



+

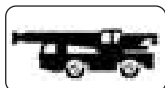

	1	2	3	4	5	6	R1	R2	R3	
km/h	2	3	6	8	18	24	2	6	18	73%
	23.5 x 25									



+



	Infinitely variable Stufenlos Progressivement variable Infinitamente variable	Rope Seil Câble Cable	Max. Single line pull Max. Seilzug Effort maxi au brin simple Tiro máximo por ramal
	0 - 171 m/min single line für einfachen Strang au brin simple ramal simple	19 mm/290 m (6 x 37 class) ▲ 19 mm/290 m (35 x 7 class)	7620 kg 7620 kg
	0 - 171 m/min single line für einfachen Strang au brin simple ramal simple	19 mm/213 m (35 x 7 class)	7620 kg
	0 - 2,5 min <sup>-1</sup>		
	20° to 70° approx. 55 s ca. 55 s env. 55 s aproximadamente 55 s		
	12,8 m to 48,6 m approx. 232 s ca. 232 s env. 232 s aproximadamente 232 s		

▲ Required for 5:1 Rope F.O. S., Gefordert bei 5:1 Sicherheitsfaktor am Hubseil, Nécessaire pour coefficient de sécurité de 5:1 du câble de levage, Necesario para el factor de seguridad de 5 a 1 del cable cabrestante, Necessario per un coefficiente di sicurezza 5:1 della fune di sollevamento.

## Notes • Hinweise • Notes • Notas • Note

### Lifting capacities according to DIN/ISO • 85%

**Warning: THIS CHART IS ONLY A GUIDE. The Notes below are for illustration only and should not be relied upon to operate the crane.**

**The individual crane's load chart, operating instructions and other instruction plates must be read and understood prior to operating the crane.**

DIN/ISO: The mechanical strength complies with DIN 15018, part 3. Tipping conditions are governed by DIN 15019, part 2 and ISO 4305 standards.

They also take into account the requirements of prEN 13000: 1997 and therefore comply with the requirements of the EU machinery directive.

85%: Capacities are in accordance with SAE J1063 and do not exceed 85% of the tipping load (SAE J1289 for outriggers 50% and 0% extended) as determined by SAE J765.

- Capacities given do not include the weight of hookblocks, slings, auxiliary lifting equipment and load handling devices. Their weights MUST be added to the load to be lifted. When more than minimum required reeving is used, the additional rope weight shall be considered part of the load.
- All capacities are for crane on firm, level surface. It may be necessary to have structural supports under the outrigger floats or tyres to spread the load to a larger bearing surface.
- When either boom length or radius or both are between values listed, the smallest load shown at either the next larger radius or boom length shall be used.
- For outrigger operation, ALL outriggers shall be fully extended with tyres raised free of ground before raising the boom or lifting loads.
- Tyres shall be inflated to the recommended pressure before lifting on rubber.

### Traglasten entsprechen DIN/ISO • 85%

**WARNUNG: DIESE TABELLE IST LEDIGLICH EINE RICHTLINIE. Die Hinweise dienen als Erklärung und sind für die Kranbedienung nicht maßgebend. Vor Inbetriebnahme des Kranes sind Traglasttabellen, Bedienungsanleitung und andere Vorschriften eingehend zu studieren.**

DIN/ISO: Der Festigkeitsberechnung liegen die DIN 15018 Teil 3 zugrunde. Die Traglasten im Standsicherheitsbereich entsprechen DIN 15019 Teil 2 und ISO 4305. Sie berücksichtigen außerdem die Forderungen von prEN 13000: 1997 und entsprechen damit den Anforderungen der Maschinenrichtlinie.

85%: Tragkraftwerte entsprechen SAE J1063 und überschreiten nicht 85 % der Kipplast (SAE J1289 bei halb- bzw. ganz ausgefahrener Abstützung) gemäß Richtlinien SAE J 765.

- Das Gewicht der Hakenflaschen und aller Anschlagmittel muß zu der Last hinzugerechnet werden. Beim Einscheren mit erhöhten Werten ist das zusätzliche Seilgewicht als Teil der Last zu betrachten.
- Alle Werte gelten für den Kran auf festem, ebenem Untergrund. Eventuell müssen die Stützsteller oder Reifen unterlegt werden, um die Last über eine größere Abstützfläche zu verteilen.
- Wenn Auslegerlänge oder Radius oder beide Werte zwischen den aufgeführten Werten liegen, ist die geringere der Traglasten zu wählen, die für den die nächstgrößere Ausladung oder die nächste bzw. anschließende Auslegerlänge genannt sind.
- In abgestütztem Zustand müssen ALLE Stützen komplette ausgefahren sein. Die Reifen dürfen den Boden nicht berühren. Erst danach dürfen Lasten oder der Ausleger angehoben werden.
- Bevor frei auf Rädern gearbeitet wird, müssen, die Reifen mit dem vorschrittsmäßigen Druck aufgefüllt werden.

### Capacités de levage selon DIN/ISO • 85%

**ATTENTION: CE TABLEAU N'EST QU'UN GUIDE. Les notes ci-dessous sont données à titre d'exemple et ne devront pas être utilisées pour faire fonctionner la grue. Toute la documentation concernant chaque type de grue: tableau des charges, instructions de fonctionnement et toutes autres plaques d'instructions devront être lues et comprises avant de manoeuvrer la grue.**

DIN/ISO: Les limites du basculement sont conformes à la norme DIN 15019 section 2 et ISO 4305. Elles tiennent également compte des paramètres établis pour le projet de norme Européenne prEN 13000: 1997 et de ce fait satisfont les exigences de la Directive Européenne Machines.

85%: Les capacités de levage sont conformes à la norme SAE J1063 et ne dépassent pas 85% de la charge de basculement (SAE J1289 pour les poutres de calage déployées à 50% et 0%) tel que cela est prescrit par la norme SAE J765.

- Les charges mentionnées dans les tableaux ne comprennent pas le poids des mouffes, des élingues et autres accessoires de levage qui doit être additionné à celui de la charge levée. Lorsque le mouffage est supérieur au minimum requis le poids de l'excédent de câble doit être additionné à celui de la charge.
- Les capacités sont données sur sol ferme et de niveau. Il peut être nécessaire d'utiliser des bastaings ou des accessoires similaires afin de répartir la charge transmise au sol par les roues ou les patins de calage.
- Lorsque la longueur de flèche ou la portée ne correspond pas aux valeurs mentionnées dans les tableaux, il convient de se référer à la valeur inférieure mentionnée pour la portée ou la longueur de flèche immédiatement supérieure.
- Pour utilisation machine calée, les poutres de calage doivent être totalement télescopées et les roues décollées du sol avant de relever la flèche ou de lever des charges.
- Les pneumatiques devront être gonflés aux pressions préconisées avant tout levage en libre.

### Capacidades de elevación de acuerdo con DIN/ISO • 85%

**AVISO: ESTA TABLA ES SOLO UNA ORIENTACION. Las notas que aparecen al final de la misma solo sirven de ilustración y no deben ser tomadas como instrucciones para operar la grúa. La tabla de cargas, las instrucciones de operación y otras placas ilustrativas de cada grúa deben ser leídas y correctamente interpretadas antes de operar la grúa.**

DIN/ISO: Los analisis de resistencia están basados en las normas DIN 15018. Apartados 3. Las condiciones de vuelco están reguladas por las normas

DIN 15019 apartado 2 y ISO 4305. Tienen también cuenta de las exigencias establecidas por prEN 13000: 1997 y así cumplen con los requerimientos de las Directivas de Maquinaria UE.

85%: Capacidades de acuerdo con las Normas SAE J1063 y no exceden del 85% del momento de vuelco (Normas SAE J1289 para las cargas sobre estabilizadores extendidos al 50% o sin extender 0%) como fijan las normas SAE J765.

- Las cargas indicadas no incluyen el peso de los ganchos, eslingas, equipos auxiliares y aparejos de elevación. Sus pesos DEBEN ser añadidos al de la carga a elevar. Cuando se utilice un número de ramales de cable superior al necesario, el peso adicional del cable debe ser considerado como parte de la carga.
- Todas las capacidades corresponden a la grúa situada sobre terreno firme nivelado y uniforme. La naturaleza del terreno puede hacer necesario colocar, bajo los apoyos de los estabilizadores o bajo los neumáticos, elementos estructurales que repartan la carga sobre una mayor superficie de apoyo.
- Cuando se trabaje con longitudes de pluma o radios, intermedios entre los valores reflejados en las tablas, se considerará la carga inmediata inferior indicada en el radio o longitud de pluma inmediato superior.
- Para trabajos sobre estabilizadores, TODOS los estabilizadores estarán totalmente extendidos y los neumáticos sin tocar el suelo antes de elevar pluma o izar cargas.
- Los neumáticos deberán estar inflados a la presión recomendada antes de elevar cargas sobre neumáticos.

### Capacità di sollevamento in accordo con DIN/ISO • 85%

**ATTENZIONE: QUESTA TABELLA E' SOLO UNA GUIDA. Le note qui sotto riportate sono date a titolo d'esempio e non devono essere utilizzate per far funzionare la gru.**

**La tabella di carico, le istruzioni d'uso ed ogni altro foglio illustrativo devono essere letti e compresi prima di manovrare la gru.**

DIN/ISO: il calcolo di resistenza è basato sulle norme DIN 15018, parte 3. Le condizioni di ribaltamento sono regolate dalle norme DIN 15019 parte 2 e ISO 4305. Esse tengono conto anche dei parametri stabiliti da prEN13000: 1997 e quindi soddisfanno le richieste della Direttiva Macchine Europea.

85%: Le capacità di sollevamento sono conformi alla norma SAE J1063 e non superano l'85% del carico di ribaltamento (SAE J1289 per gli stabilizzatori estesi al 50% e 0%) come prescritto dalla norma SAE J765.

- I carichi indicati nelle tavole non comprendono il peso dei ganci, dei tiranti, e di nessun altro accessorio di sollevamento che deve essere aggiunto a quello del carico sollevato. Quando il numero di funi è superiore al minimo richiesto il peso addizionale della fune deve essere aggiunto a quello del carico.
- Tutte le capacità si intendono per la gru situata su un terreno compatto livellato e uniforme. Potrebbe rendersi necessario utilizzare dei supporti strutturali, sotto gli appoggi degli stabilizzatori o sotto i pneumatici, per ripartire il carico su una superficie di appoggio maggiore.
- Quando la lunghezza del braccio o la portata non corrispondono ai valori riportati nelle tabelle, conviene considerare il valore inferiore riportato per il raggio di lavoro o la lunghezza del braccio immediatamente superiore.
- Per lavori su stabilizzatori, TUTTI gli stabilizzatori devono essere completamente estesi e i pneumatici staccati da terra prima di rialzare il braccio o di sollevare carichi.
- I pneumatici devono essere gonfiati alla pressione raccomandata prima di sollevare carichi sopra i pneumatici.

Load charts • Traglasten • Capacités de levage • Capacidades • Capacità

Working range • Arbeitsbereiche • Diagramme de levage • Gama de trabajo • Area di lavoro



12.8 – 48.6 m



11/18 m



360°

11

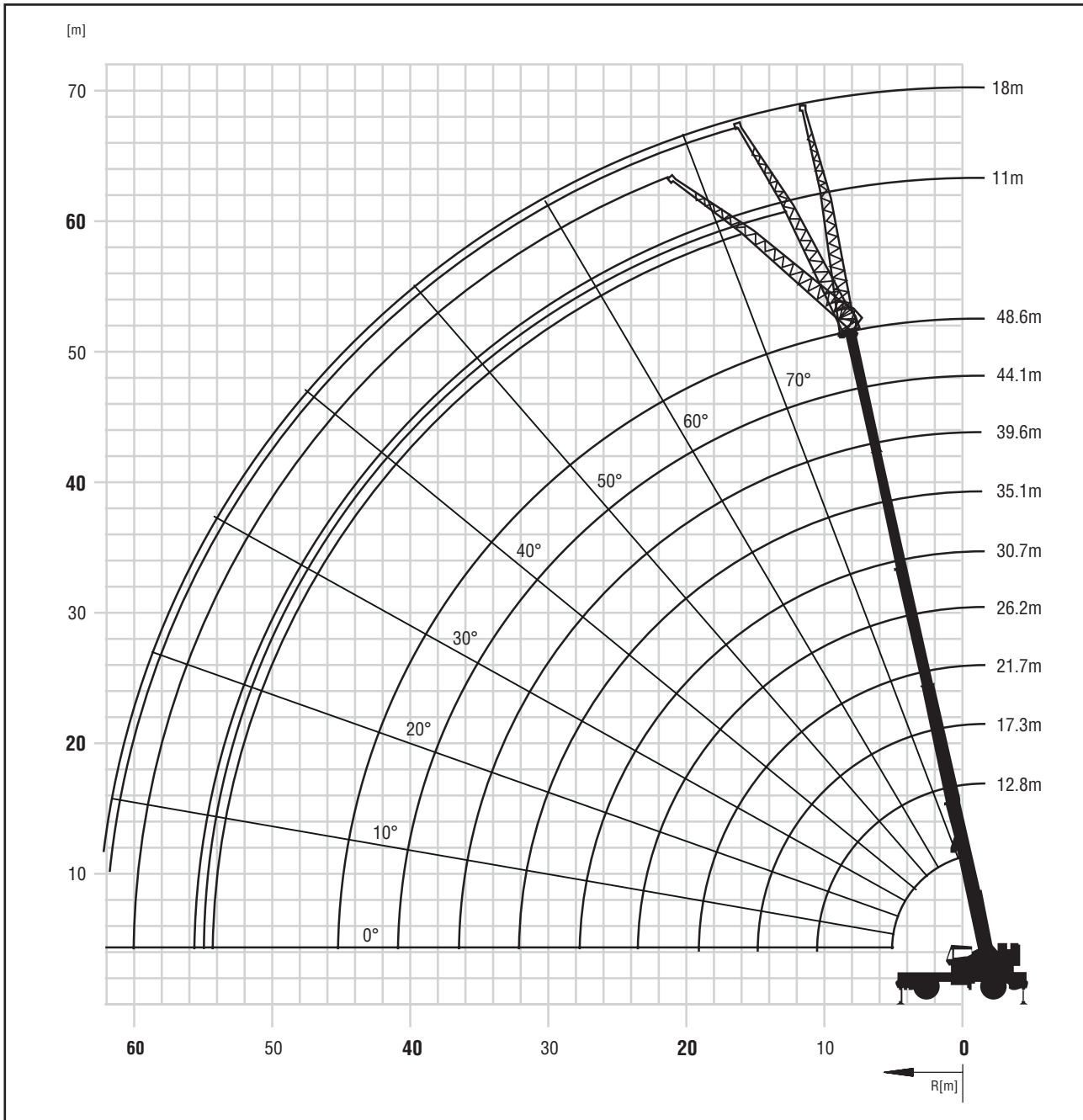

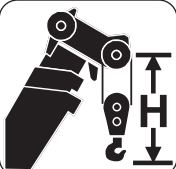
	Hook block • Unterflasche • Crochet-moufle • Gancho (t)	H (mm)
	115	3353
70	3353	
9.1 H/B	2946	
—	—	

RT9130E

Load charts • Traglasten • capacités de levage • Capacidades • Capacità

Telescopic boom • Teleskopausleger • Flèche principale • Pluma telescópica • Braccio telescopico

12



12.8 – 48.6 m



100%



360°



18,144 kg



DIN/ISO

m	12.8	17.3	21.7	26.2	30.7	35.1	39.6	44.1	48.6
3.0	110,000	66,675							
3.5	104,500	66,675							
4.0	92,900	66,675	54,900						
4.5	81,525	66,675	54,200						
5.0	72,975	63,925	53,500	40,900					
6.0	59,200	57,525	52,175	39,425	29,450				
7.0	49,700	48,850	46,950	37,200	28,725	20,225			
8.0	41,825	41,025	40,925	34,600	27,750	20,225			
9.0	35,750	35,000	34,900	31,500	26,000	20,225	17,750		
10.0	26,400	30,475	30,375	28,925	24,025	20,225	17,400	14,000	
12.0		23,400	23,350	23,475	20,300	18,950	16,675	13,525	10,950
14.0		17,600	18,450	18,650	17,300	16,625	15,250	13,050	10,625
16.0			14,825	15,050	14,675	14,375	13,725	12,475	10,150
18.0			11,975	12,200	12,075	12,475	12,175	11,375	9,780
20.0				9,950	9,865	10,625	10,675	10,275	9,380
22.0				8,155	8,050	8,900	9,330	9,090	8,370
24.0				4,815	6,530	7,395	7,930	7,970	7,340
26.0					5,230	6,095	6,750	6,985	6,450
28.0					3,475	4,875	5,660	6,025	5,780
30.0						3,845	4,620	5,120	5,275
32.0						2,585	3,730	4,235	4,630
34.0							2,955	3,455	3,935
36.0							2,280	2,775	3,260
38.0								2,175	2,655
40.0								1,645	2,120
42.0								690	1,640

A6-829-102217



85%

m	12.8	17.3	21.7	26.2	30.7	35.1	39.6	44.1	48.6
3.0	120,000	66,675							
3.5	105,750	66,675							
4.0	92,900	66,675	57,600						
4.5	81,525	66,675	57,600						
5.0	72,975	63,925	56,125	42,000					
6.0	59,200	57,525	52,700	39,425	29,475				
7.0	49,700	48,850	46,950	37,200	28,850	20,225			
8.0	41,825	41,025	40,925	34,600	27,750	20,225			
9.0	35,750	35,000	34,900	31,500	26,000	20,225	19,575		
10.0	26,400	30,475	30,375	28,925	24,025	20,225	19,325	14,750	
12.0		23,400	23,350	23,475	20,300	18,950	17,475	14,750	11,375
14.0		17,600	18,450	18,650	17,300	18,625	15,250	14,500	11,200
16.0			14,825	15,050	14,675	14,375	13,725	12,750	11,000
18.0			11,975	12,200	12,075	12,475	12,175	11,375	10,575
20.0				9,980	9,865	10,625	10,675	10,275	9,460
22.0				8,155	8,050	8,900	9,330	9,090	8,370
24.0				4,815	6,530	7,395	7,930	7,970	7,340
26.0					5,230	6,095	6,750	6,985	6,450
28.0					3,475	5,020	5,660	6,025	5,780
30.0						4,065	4,720	5,185	5,275
32.0						2,585	3,915	4,415	4,630
34.0							3,165	3,680	3,960
36.0							2,510	3,035	3,415
38.0								2,455	2,870
40.0								1,800	2,335
42.0								690	1,865



A6-829-102216

RT9130E

# Load charts • Traglasten • Capacités de levage • Capacidades • Capacità

## Telescopic boom • Teleskopausleger • Flèche principale • Pluma telescópica • Braccio telescopico

13





 12.8 – 48.6 m
  50%
  360°
  18,144 kg



**DIN/ISO & 85%**

m	12.8	17.3	21.7	26.2	30.7	35.1	39.6	44.1	48.6
3.0	109,500	66,675							
3.5	100,750	66,675							
4.0	91,025	66,675	57,600						
4.5	81,100	66,675	57,600						
5.0	72,975	63,925	56,125	41,225					
6.0	59,200	56,825	51,675	39,425	29,475				
7.0	49,700	44,925	41,250	37,200	28,850	20,225			
8.0	39,650	36,700	33,875	31,950	27,750	20,225			
9.0	31,975	30,625	28,425	26,925	25,225	20,225	19,575		
10.0	26,400	25,075	24,200	23,025	21,600	20,225	19,325	14,750	
12.0		17,675	17,450	17,300	16,250	16,475	16,525	14,750	11,375
14.0		12,975	12,700	13,225	12,500	12,900	13,075	13,175	11,200
16.0			9,440	9,865	9,740	10,200	10,500	10,675	10,750
18.0			7,040	7,380	7,365	8,110	8,495	8,725	8,865
20.0				5,475	5,445	6,210	6,885	7,155	7,340
22.0				3,975	3,930	4,685	5,405	5,870	6,085
24.0				2,760	2,705	3,450	4,165	4,665	5,030
26.0					1,695	2,430	3,140	3,640	4,115
28.0					840	1,570	2,275	2,770	3,255
30.0						840	1,540	2,030	2,510
32.0							905	1,395	1,865
34.0								835	1,305
36.0									815

A6-829-102218

 12.8 – 26.2 m
  33.25 x 29
  0°
  18,144 kg



**DIN/ISO & 85%**

< 4 kph				
m	12.8	17.3	21.7	26.2
0°				
3.0	28,000			
3.5	28,000			
4.0	25,600			
4.5	22,675	15,675		
5.0	20,300	15,675		
6.0	16,150	15,675		
7.0	15,750	15,675		
8.0	15,125	14,925		
9.0	13,475	13,050	12,000	
10.0	11,700	11,200	11,275	
12.0		8,295	8,320	8,985
14.0		6,090	6,055	6,600
16.0			4,280	4,710
18.0			2,850	3,190
20.0				1,940
22.0				900

A6-829-102219/63

0° = over front, über Vorderkante, sur avant, per la parte frontal, per la parte frontale

Load charts • Traglasten • Capacités de levage • Capacidades • Capacità

Swingaway/Lattice extension • Doppelklappspitze/Auslegerverlängerung • Extension treillis • Plumin • Jib

14



39.6 – 48.6 m



11/18/  
26/34 m



100%



360°



18,144 Kg



DIN/ISO

m		39.6			48.6			39.6			48.6		
m		11			11			18			18		
		0°	20°	40°	0°	20°	40°	0°	20°	40°	0°	20°	40°
10,0	10,575												
12,0	10,500							5,575					
14,0	10,100	9,280			6,520			5,575					
16,0	9,855	8,935	7,415		6,380			5,575			4,360		
18,0	9,555	8,620	7,255		6,240	6,425		5,575	4,480		4,360		
20,0	9,205	8,335	7,120		6,105	6,285	6,560	5,575	4,480		4,295		
22,0	8,835	8,070	7,000		5,970	6,150	6,430	5,575	4,480	3,825	4,235	4,375	
24,0	7,730	7,830	6,895		5,830	6,015	6,175	5,575	4,400	3,740	4,170	4,290	
26,0	6,790	7,015	6,810		5,640	5,830	5,810	5,505	4,260	3,665	4,110	4,190	3,635
28,0	6,000	6,205	6,365		5,445	5,500	5,460	5,330	4,135	3,600	4,045	4,090	3,580
30,0	5,290	5,490	5,650		4,980	5,155	5,150	4,865	4,015	3,540	3,960	4,000	3,530
32,0	4,690	4,890	5,025		4,405	4,650	4,735	4,675	3,910	3,490	3,855	3,910	3,485
34,0	4,070	4,330	4,435		3,870	4,105	4,270	4,235	3,810	3,445	3,750	3,830	3,445
36,0	3,405	3,755	3,930		3,405	3,625	3,775	3,765	3,720	3,410	3,470	3,655	3,410
38,0	2,820	3,120	3,270		2,985	3,195	3,330	3,350	3,630	3,385	3,065	3,355	3,380
40,0	2,295	2,555	2,660		2,600	2,795	2,915	2,945	3,225	3,370	2,690	3,020	3,195
42,0	1,830	2,045			2,170	2,435	2,540	2,455	2,865	3,015	2,355	2,665	3,865
44,0	1,410	1,590			1,745	2,070	2,195	2,015	2,505	3,650	2,050	2,340	2,535
46,0		1,180			1,355	1,645	1,805	1,615	2,060	2,200	1,770	2,035	2,210
48,0					1,005	1,260	1,410	1,255	1,655		1,500	1,765	1,915
50,0					685	910		925	1,290		845	1,505	1,630
52,0						585		625	900		555	1,245	1,355
54,0												925	1,000
56,0												625	

A6-829-102234/41

m		48.6			48.6		
m		26			34		
		0°	20°	40°	0°	20°	40°
18,0	2,870						
20,0	2,870						
22,0	2,820				1,540		
24,0	2,770		2,995		1,540		
26,0	2,720		2,945		1,535		
28,0	2,670		2,895	2,900	1,495	1,655	
30,0	2,620		2,845	2,900	1,455	1,610	
32,0	2,560		2,780	2,900	1,415	1,570	1,705
34,0	2,500		2,720	2,890	1,375	1,530	1,675
36,0	2,440		2,660	2,840	1,335	1,485	1,650
38,0	2,380		2,660	2,705	1,300	1,445	1,620
40,0	2,315		2,540	2,550	1,260	1,405	1,595
42,0	2,095		2,410	2,405	1,210	1,360	1,565
44,0	1,795		2,135	2,240	1,160	1,320	1,540
46,0	1,515		1,835	2,055	1,110	1,280	1,510
48,0	1,265		1,565	1,770	1,025	1,235	1,480
50,0	1,035		1,315	1,495	800	1,125	1,305
52,0	815		1,075	1,235		890	1,095
54,0	620		860	1,000			865
56,0			660	775			

A6-829-102259

RT9130E

# Load charts • Traglasten • Capacités de levage • Capacidades • Capacità

## Swingaway/Lattice extension • Doppelklappspitze/Auslegerverlängerung • Extension treillis • Plumin • Jib



39.6 – 48.6 m



11/18/  
26/34 m



100%



360°



18,144 Kg

15

**85%**

	39.6			48.6			39.6			48.6		
	11			11			18			18		
	0°	20°	40°	0°	20°	40°	0°	20°	40°	0°	20°	40°
10,0	10,575											
12,0	10,575						5,575					
14,0	10,575	9,610		7,255			5,575					
16,0	10,575	9,250	7,595	7,235			5,575			4,580		
18,0	10,575	8,895	7,435	7,190	7,120		5,575	5,290		4,580		
20,0	10,000	8,590	7,285	7,160	7,080	6,865	5,575	5,105		4,580		
22,0	8,835	8,300	7,150	6,985	6,665	6,560	5,575	4,915	4,095	4,580	4,555	
24,0	7,730	7,865	7,045	6,525	6,245	6,175	5,575	4,750	4,000	4,580	4,555	
26,0	6,790	7,015	6,915	6,080	5,585	5,810	5,575	4,595	3,920	4,580	4,550	3,895
28,0	6,000	6,205	6,365	5,620	5,500	5,460	5,510	4,455	3,845	4,580	4,445	3,780
30,0	5,290	5,490	5,650	4,980	5,155	5,150	5,255	4,320	3,780	4,460	4,315	3,780
32,0	4,690	4,890	5,025	4,405	4,650	4,735	4,770	4,200	3,720	4,210	4,105	3,730
34,0	4,140	4,330	4,435	3,870	4,105	4,270	4,235	4,080	3,670	3,910	3,870	3,660
36,0	3,655	3,835	3,930	3,405	3,625	3,775	3,765	3,960	3,635	3,470	3,655	3,530
38,0	3,130	3,360	3,470	2,985	3,195	3,330	3,350	3,630	3,550	3,065	3,355	3,385
40,0	2,605	2,890	2,890	2,600	2,795	2,915	2,965	3,225	3,400	2,690	3,020	3,195
42,0	2,150	2,385		2,260	2,435	2,540	2,620	2,865	3,015	2,355	2,665	2,865
44,0	1,730	1,910		1,930	2,110	2,195	2,255	2,530	2,650	2,050	2,340	2,535
46,0		1,300		1,605	1,795	1,865	1,880	2,200	2,200	1,770	2,035	2,210
48,0				1,260	1,460	1,500	1,535	1,840		1,515	1,765	1,915
50,0				940	1,125		1,210	1,470		1,265	1,505	1,630
52,0				600	600		800	900		1,015	1,260	1,365
54,0										745	1,015	1,115
56,0											745	

A6-829-102233/40

	48.6			48.6		
	26			34		
	0°	20°	40°	0°	20°	40°
18,0	3,205					
20,0	3,205					
22,0	3,205			1,995		
24,0	3,205	2,995		1,995		
26,0	3,205	2,995		1,995		
28,0	3,205	2,995	2,900	1,995	1,915	
30,0	3,205	2,995	2,900	1,995	1,915	
32,0	3,205	2,995	2,900	1,995	1,915	1,810
34,0	3,160	2,985	2,890	1,995	1,915	1,810
36,0	2,960	2,950	2,840	1,995	1,915	1,810
38,0	2,705	2,805	2,705	1,995	1,915	1,810
40,0	2,420	2,615	2,550	1,960	1,915	1,810
42,0	2,095	2,410	2,405	1,790	1,890	1,810
44,0	1,795	2,135	2,240	1,545	1,775	1,725
46,0	1,515	1,835	2,055	1,270	1,600	1,600
48,0	1,265	1,565	1,770	1,025	1,360	1,480
50,0	1,035	1,315	1,495	800	1,125	1,305
52,0	815	1,075	1,235		890	1,095
54,0	620	860	1,000			865
56,0		660	775			

A6-829-102247

RT9130E

Load charts • Traglasten • Capacités de levage • Capacidades • Capacità

Swingaway/Lattice extension • Doppelklappspitze/Auslegerverlängerung • Extension treillis • Plumin • Jib

16



39.6 – 48.6 m



11/18 m



50%



360°



18,144 Kg



DIN/ISO & 85%

m		39.6			48.6			39.6			48.6		
m		11			11			18			18		
		0°	20°	40°	0°	20°	40°	0°	20°	40°	0°	20°	40°
10,0	10,575												
12,0	10,500							5,575					
14,0	10,100	9,280			6,520			5,575					
16,0	9,855	8,935	7,415		6,380			5,575				4,360	
18,0	8,660	8,620	7,255		6,240	6,425		5,575	4,480			4,360	
20,0	7,165	8,100	7,120		6,105	6,285	6,560	5,575	4,480			4,295	
22,0	5,935	6,765	7,000		5,970	6,150	6,430	5,575	4,480	3,825		4,235	4,375
24,0	4,905	5,645	6,255		5,025	5,740	6,175	5,335	4,400	3,740		4,170	4,290
26,0	4,030	4,690	5,220		4,180	4,830	5,365	4,475	4,260	3,665		4,110	4,190
28,0	3,280	3,865	4,325		3,455	4,045	4,505	3,740	4,135	3,600		3,750	4,090
30,0	2,605	3,145	3,515		2,820	3,355	3,720	3,095	3,975	3,540		3,125	4,000
32,0	1,980	2,445	2,755		2,265	2,750	3,035	2,530	3,330	3,490		2,580	3,385
34,0	1,435	1,835	2,090		1,775	2,215	2,445	2,025	2,750	3,335		2,095	2,835
36,0	960	1,300	1,510		1,335	1,735	1,925	1,560	2,235	2,745		1,660	2,340
38,0	535	825	995		920	1,300	1,465	1,145	1,770	2,215		1,270	1,895
40,0			535		545	900	1,050	780	1,340	1,725		915	1,490
42,0						510	685		940	1,240		595	1,120
44,0									580	800			785
46,0													770

A6-829-102235

RT9130E

GROVE



**Weight reductions • Gewichte der Lastaufnahmemittel • Reductions de charge  
Reducciones de peso • Riduzioni di peso**

<b>Auxiliary boom nose</b> / Zusatz-Auslegerkopf / <i>Tête de flèche auxiliaire</i> / <i>Cabeza auxiliar</i> / <i>Falconcino ausiliario in testa al braccio</i>	54 kg
<b>Hookblocks</b> / Hakenflaschen / <i>Mouffles</i> / <i>Ganchos</i> / <i>Ganci</i>	
<b>72 tonne 5 sheave</b> / Seilrollen / <i>reas</i> / <i>poleas</i> / <i>carrucole</i>	726 kg
<b>118 tonne 8 sheave</b> / Seilrollen / <i>reas</i> / <i>poleas</i> / <i>carrucole</i>	1089 kg
<b>9.1 tonne swivel hook and weight</b> / Hakengeschirr / Einseilhaken / <i>crochet lesté</i> / <i>gancho y bola</i> / <i>gancio &amp; peso</i>	308 kg
<b>11 m Extension</b> / Klappspitze / <i>Prolongacion</i> / <i>Estensione</i>	
<b>Erected</b> / Arbeitsstellung / <i>En position de travail</i> / <i>montada</i> / <i>Montato</i>	2,386 kg
<b>18 m Extension</b> / Klappspitze / <i>Prolongacion</i> / <i>Estensione</i>	
<b>Erected</b> / In Arbeitsstellung / <i>En position de travail</i> / <i>Montado</i> / <i>Montato</i>	4,472 kg
<b>26 m Extension</b> / Verlängerung / <i>Prolongacion</i> / <i>Estensione</i>	
<b>Erected</b> / In Arbeitsstellung / <i>En position de travail</i> / <i>Montado</i> / <i>Montato</i>	6,396 kg
<b>34 m Extension</b> / Verlängerung / <i>Prolongacion</i> / <i>Estensione</i>	
<b>Erected</b> / In Arbeitsstellung / <i>En position de travail</i> / <i>Montado</i> / <i>Montato</i>	8,800 kg

**NOTE:**  
All load handling devices and boom attachments are considered part of the load and suitable allowances must be made for their combined weights.

**HINWEIS:**  
Alle Lastaufnahmemittel und jede Zusatzausrüstung des Hauptauslegers werden als Teil der Traglast betrachtet und ihre kombinierten Gewichte müssen beim Feststellen der Nettolast entsprechend berücksichtigt (abgezogen) werden.

**REMARQUE:**  
Les équipements complémentaires et accessoires de levage sont considérés comme faisant partie de la charge; les réductions de charges de leurs poids combinés doivent être effectuées.

**NOTA:**  
Todos los aparos de elevacion e implementos de pluma son considerados parte de la carga y deben ser tenidos en cuenta para calcular los pesos a elevar.

**NOTA:**  
Tutti gli accessori di sollevamento e le opzioni montate sul braccio sono considerati parte del carico e devono essere richieste adeguate autorizzazioni per l'uso dei loro pesi complessive.

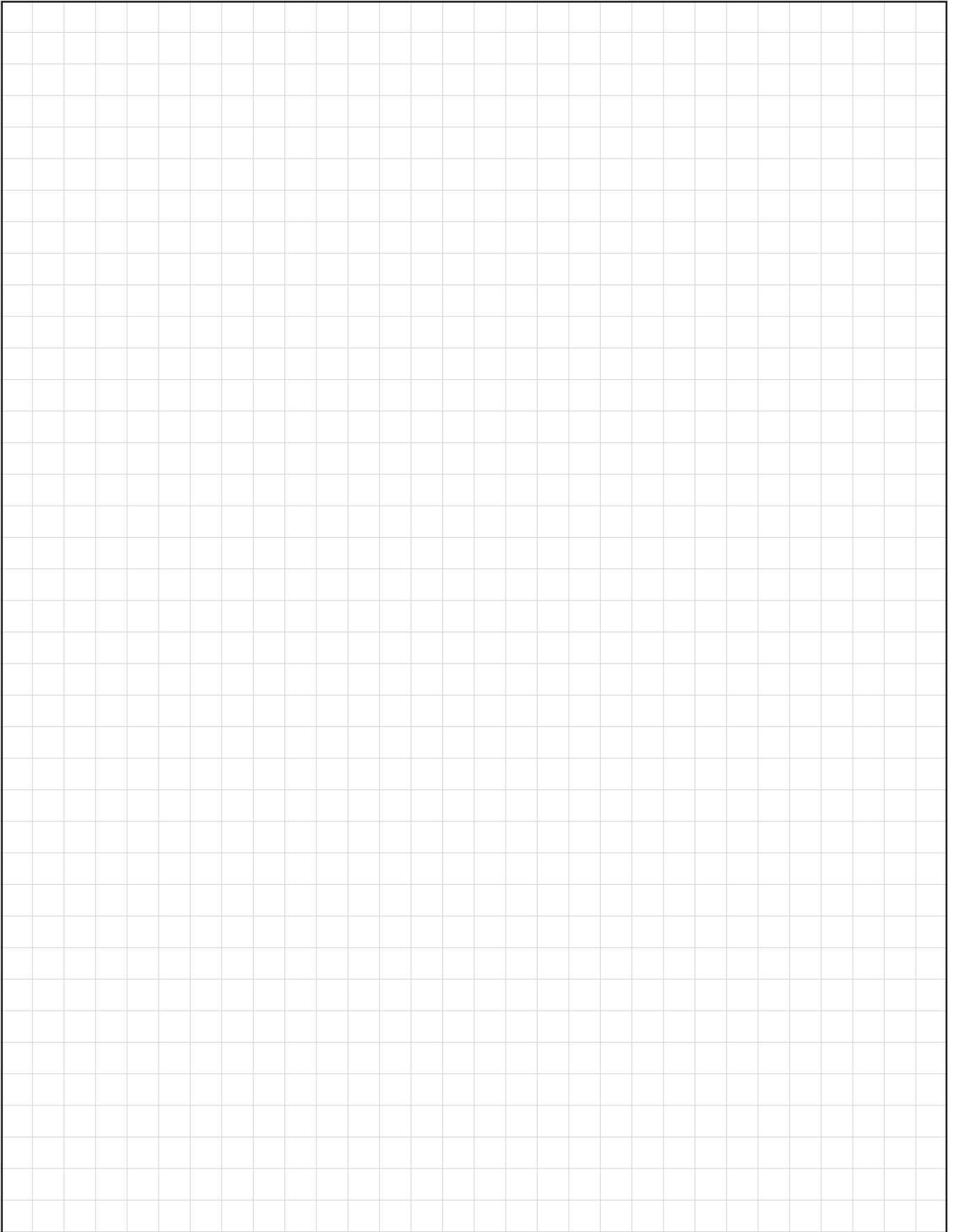

Symbols • Symbolerklärung • Glossaire des symboles • Glosario de simbolos • Glossario dei simboli



Axles  
Achsen  
Ponts  
Ejes  
Assali



Crane functions  
Kranbewegungen  
Mouvements de la grue  
Funciones de la grúa  
Funzioni della gru



Hookblock / Capacity  
Hakenflasche / Traglast  
Moufle / Force de levage  
Gancho / Capacidad  
Gancio / Capacità



Speed  
Geschwindigkeit  
Vitesse  
Velocidad  
Velocità



Axle load  
Achslast  
Charge à l'essieu  
Carga por eje  
Carico sugli assi



Crane travel  
Fahrstellung  
Déplacement de la grue  
Grúa en traslado  
Traslazione gru



Hydraulic system  
Hydrauliksystem  
Circuit hydraulique  
Sistema hidráulico  
Impianto idraulico



Suspension  
Federung  
Suspension  
Suspensión  
Sospensioni



Boom  
Ausleger  
Flèche  
Pluma  
Braccio



Drive/Steer  
Antrieb/Lenkung  
Direction/Déplacement  
Tracción/Dirección  
Trazione/Sterzo



Lattice extension  
Gitterspitze  
Extension treillis  
Extensión de celosía  
Lunghezza prolunga



Transmission / Gear  
Getriebe / Gang  
Boîte de vitesses / Rapport  
Transmisión / Cambio  
Cambio



Boom elevation  
Wippwerk  
Relevage  
Elevacion de pluma  
Elevazione braccio



Electrical system  
Elektrische Anlage  
Circuit électrique  
Sistema eléctrico  
Impianto elettrico



Lattice extension (luffing)  
Auslegerverlängerung (wippbar)  
Extension treillis (volée variable)  
Extensión de celosía (angulable hidráulicamente)



Travel speed  
Fahrgeschwindigkeit  
Vitesse de déplacement  
Velocidad de desplazamiento  
Velocità di traslazione



Boom telescoping  
Teleskopieren  
Télescopage de flèche  
Telescopaje de pluma  
Lunghezza braccio



Engine  
Motor  
Moteur  
Motor  
Motore



Luffing Jib  
Wippspitzenausleger  
Volée variable  
Plumín angulable



Tyres  
Bereifung  
Pneumatiques  
Neumáticos  
Pneumatici



Brakes  
Bremsen  
Freins  
Frenos  
Freni



Free on wheels  
Freistehend  
Sur pneus  
Sobre neumáticos  
Su gomme



Low range  
Kleinste Übersetzung  
Gamme basse  
Marchas cortas  
Fuoristrada



Cab  
Kabine  
Cabine  
Cabina  
Cabina



Gradeability  
Steigtätigkeit  
Aptitude en pente  
Superacion de pendientes  
Pendenza superabile



Outriggers  
Abstützung  
Calage  
Estabilizadores  
Stabilizzatori



Carrier frame  
Rahmen  
Châssis porteur  
Bastidor  
Telaio



Main hoist  
Haupthubwerk  
Trebil principal  
Cabrestante principal  
Argano principale



Radius  
Ausladung  
Portée  
Radio  
Raggio



Counterweight  
Gegengewicht  
Contrepoids  
Contrapeso  
Contrappeso



Auxiliary hoist  
Hilfshubwerk  
Trebil auxiliaire  
Cabrestante auxiliar  
Argano secundario



Slewing/Working range  
Drehwerk/Arbeitsbereich  
Orientation/Rayon d'operation  
Giro/Gama de trabajo  
Rotazione/Area di lavoro



**Manitowoc Crane Group - Americas**

Tel: [Int + 001] 920 684 6621

Fax: [Int + 001] 920 683 6277

**Manitowoc Crane Group - EMEA**

Europe Middle East & Africa

Tel: [Int + 33] (0) 4 72 18 20 20

Fax: [Int + 33] (0) 4 72 18 20 00

**Manitowoc Crane Group - UK**

Europe Middle East & Africa (Parts & Service)

Tel: [Int + 44] (0) 191 565-6281

Fax: [Int + 44] (0) 191 564-0442

**Manitowoc Crane Group - Germany**

(Sales, Parts & Service)

Tel: [Int + 49] (0) 2173 8909-0

Fax: [Int + 49] (0) 2173 8909-30

**Manitowoc Crane Group - France**

France & Africa (Sales, Parts & Service)

Tel: [Int + 33] (0) 1 303-13150

Fax: [Int + 33] (0) 1 303-86085

**Manitowoc Crane Group - Netherlands**

(Sales, Parts & Service)

Tel: [Int + 31] (0) 76 578 39 99

Fax: [Int + 31] (0) 76 578 39 78

**Manitowoc Crane Group - Italy**

Italy & Southern Europe (Sales, Parts & Service)

Tel: [Int + 39] (0) 331 49 33 11

Fax: [Int + 39] (0) 331 49 33 30

**Manitowoc Crane Group - Portugal**

Portugal & Spain (Sales, Parts & Service)

Tel: [Int + 351] (0) 22 968 08 89

Fax: [Int + 351] (0) 22 968 08 97

**Manitowoc Crane Group - Singapore**

Asia/Pacific excl China (Sales, Parts & Service)

Tel: [Int + 65] 6861-7133

Fax: [Int + 65] 6862-4040 / 4142

**Manitowoc Crane Group - Shanghai**

China (Sales, Parts & Service)

Tel: [Int + 86] (0) 21-64955555

Fax: [Int + 86] (0) 21-64852038

**Manitowoc Crane Group - Beijing**

China (Sales, Parts & Service)

Tel: [Int + 86] (0) 10 646-71690

Fax: [Int + 86] (0) 10 646-71691

**Manitowoc Crane Group - Middle East**

(Sales)

Tel: [Int + 971] (0) 4 348-4478

Fax: [Int + 971] (0) 4 348-4478

(Parts & Service)

Tel: [Int + 973] (0) 9 660-899

Fax: [Int + 973] (0) 2 707-740

**Distributed By:**



[www.manitowoccrane.com](http://www.manitowoccrane.com)



Constant improvement and engineering progress make it necessary that we reserve the right to make specification, equipment, and price changes without notice. Illustrations shown may include optional equipment and accessories and may not include all standard equipment.

Wir verbessern unsere Produkte ständig und integrieren den technischen Fortschritt. Aus diesem Grund behalten wir uns das Recht vor, die technischen Daten, die Ausstattungsdetails und die Preise unserer Maschinen ohne Vorankündigung zu ändern.

Du fait de sa politique d'amélioration constante de ses produits liée au progrès technique, la Société se réserve le droit de procéder sans préavis à des changements de spécifications, d'équipement ou de prix. Les illustrations peuvent comporter des équipements ou accessoires optionnels ou ne pas comporter des équipements standards.

El perfeccionamiento constante y el avance tecnológico hacen necesario que la empresa se reserve el derecho de efectuar cambios en las especificaciones, equipo y precios sin previo aviso. En las ilustraciones se puede incluir equipo y accesorios opcionales y es posible que no se muestre el equipo normal.

Dati e caratteristiche possono variare senza obbligo di preavviso.